

Est. 1991

DESIGNSUPPLY   
supporting creativity

# THE MAGNIFICENT 8 FEATURES OF THE imagePROGRAF GP-300/200

**Canon**

---



# YOUR PERFECT PRINTER WILL:

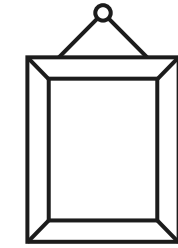

**PRINT IN EXCELLENT QUALITY**

**ACHIEVE A PANTONE CALIBRATED LICENSE**



**MAKE POSTER CREATION EASY**

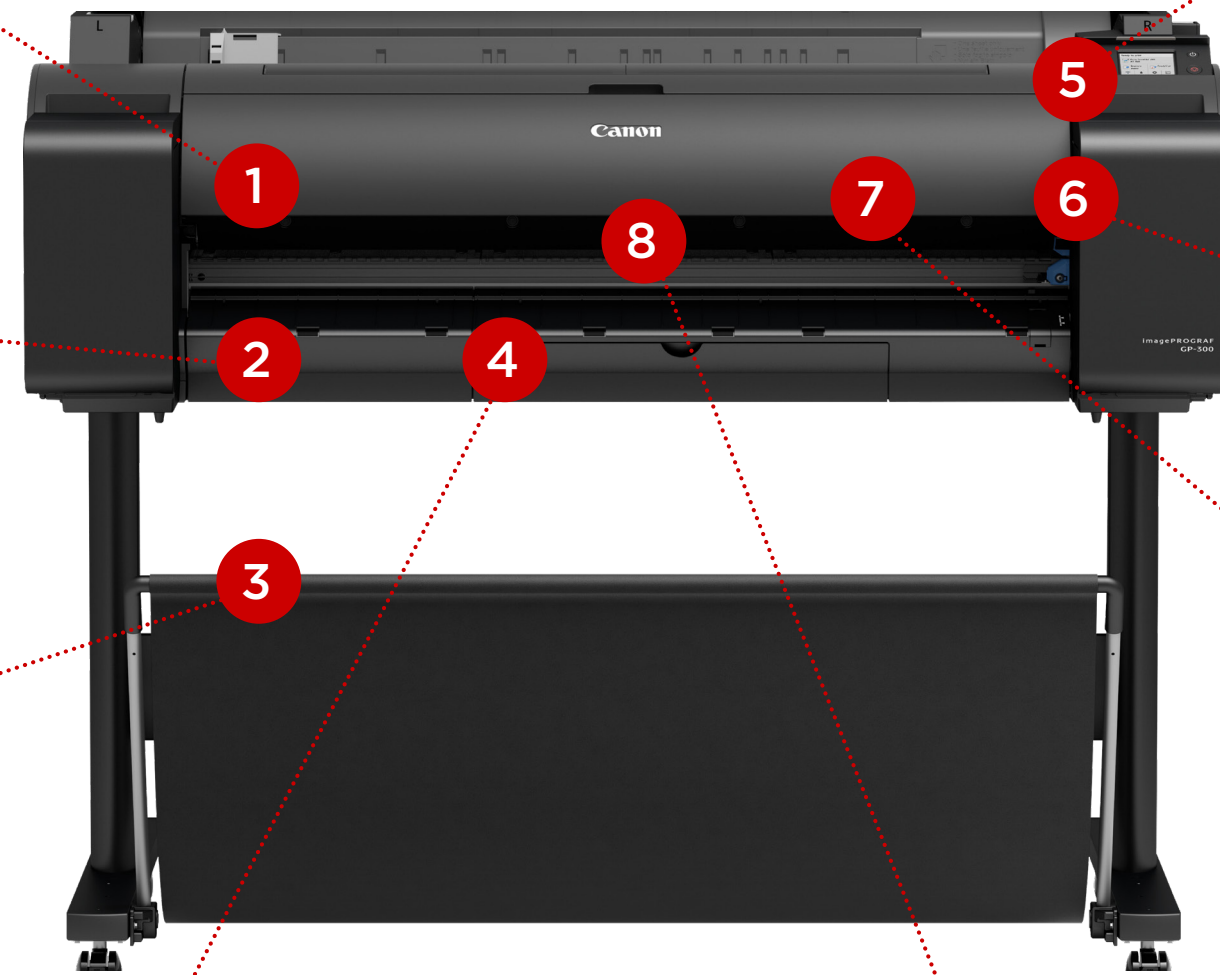

**PRINT FLUORESCENT COLOURS**



**PRODUCE WATER-RESISTANT PRINTS**



**PRINT WITHOUT BORDERS**

**FIT INTO COMPACT SPACES**

**DIRECT PRINT FROM HDD/USB**

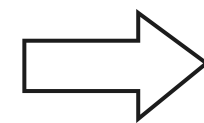

## 1. EXCELLENT QUALITY WITH FLUORESCENT PINK

Thinking of printing posters? Think pink! The imagePROGRAF GP-300 and GP-200 printers feature incredible new Fluorescent Pink ink along with CMYK and Matte Black to achieve excellent colour reproduction and image quality.

Explore your creativity by adding Fluorescent Pink highlights to your poster graphics with the new Spot mode or use Vivid mode to automatically add the perfect level of vibrancy to the design.

## 2. PANTONE® CALIBRATED LICENSE

Canon imagePROGRAF GP-300 and GP-200 printers have achieved the “PANTONE® Calibrated license for PANTONE PASTELS & NEONS GUIDE Coated”, which includes fluorescent and pastel colours.<sup>2</sup>

This means you can be confident that you can print neon brights and soft pastels that are true to your original design.

## 3. SUPER-SIMPLE POSTER CREATION

It's quick and simple to design unique posters and other graphics thanks to the latest PosterArtist software, bundled with each printer.

As well as an extensive range of poster templates, PosterArtist gives you access to millions of JPEG, PNG, TIFF and BMP images from Pixabay, Unsplash and Pexels stock photo libraries. Choose a template, select the perfect picture, add your own text and print in high quality, in-house.

## 4. A CHOICE OF MEDIA

Print with vivid colours on your choice of paper, including uncoated, coated or photo paper, with brilliant results.

Use the default setting to print with Fluorescent Pink ink – perfect for eye-catching short-term poster applications – or choose to use the basic colour options for high-quality posters on a variety of media. Explore everything from glossy paper posters with uniform lustre to plain paper with crisp black shades.

## 5. WATER-RESISTANT PRINTS

Innovative LUCIA TD inks have proven water resistance, so you can display your poster creations in any location, indoors or out.

Print tough and outdoor-durable posters in-house – perfect for communicating key messages in retail, hospitality, education, healthcare and more.

## 6. BORDERLESS PRINTING

Advanced multisensor algorithms detect the edge of the paper and make highly accurate margin adjustments, allowing you to print across the full area of the media.

Complete fully borderless printing using a combination of paper sizes or print borderless on three sides when paper sizes don't fit the width of the roll and easily trim the excess.

## 7. COMPACT SIZE

The imagePROGRAF GP-300 and GP-200 printers have a sleek, compact design to allow easy installation in small spaces such as offices and retail environments.

All operations related to printing, including removing printouts and setting and replacing roll paper and ink tanks, are performed from the front of the printer so it can be fitted flush against a wall.

## 8. DIRECT PRINT FROM HDD/USB MEMORY

Print JPG and PDF files directly from the printer's HDD or a USB memory stick, making the process quick and easy.

Thanks to the display screen's preview function, you don't need a PC to check files or pages are correct before starting the printing process.

<sup>1</sup>PANTONE® is a trademark or registered trademark of Pantone LLC.

<sup>2</sup>“PANTONE PASTELS & NEONS GUIDE Coated” colour gamut coverage rate is 85% for imagePROGRAF GP-300/200 when using Premium Semi-Glossy Paper 2 with imagePROGRAF printer driver at [Poster/Photo (Fluorescent)] [Highest] (600dpi).



Est. 1991  
**DESIGNSUPPLY**  
supporting creativity

E | [sales@designsupply.com](mailto:sales@designsupply.com)

T | 020 7842 1555    W | [www.designsupply.com](http://www.designsupply.com)

Unit 2, Green Lane Business Centre, New Eltham, London, SE9 3TL

**Canon**